

QX416 | Flight type dishwasher

**SKU:** 16256

### ADDITIONAL INFORMATION

<b>Weight</b>	845 kg
<b>Dimensions</b>	1185 × 5600 × 2060 mm
<b>Brand</b>	<a href="#">DIHR</a>
<b>Packaging dimension (Wi)</b>	<a href="#">5600</a>
<b>Packaging dimension (De)</b>	<a href="#">1185</a>
<b>Packaging dimension (He)</b>	<a href="#">2060</a>
<b>External size (Wi)</b>	<a href="#">5400</a>
<b>External size (De)</b>	<a href="#">985</a>
<b>External size (Hi)</b>	<a href="#">1860</a>
<b>Gross weight (kg)</b>	<a href="#">845</a>
<b>Voltage (V/Hz)</b>	<a href="#">400/50</a>
<b>Power (W)</b>	<a href="#">33500</a>
<b>Basket dimensions (mm)</b>	<a href="#">500 x 500</a>
<b>Number of baskets</b>	<a href="#">3200-4820 dishes/hour</a>
<b>Washing up efficiency (basket/hour)</b>	<a href="#">3200-4820 dishes/hour</a>
<b>Tank capacity (l)</b>	<a href="#">100</a>
<b>Maximal dish size (mm)</b>	<a href="#">450</a>
<b>Net weight (kg)</b>	<a href="#">745</a>

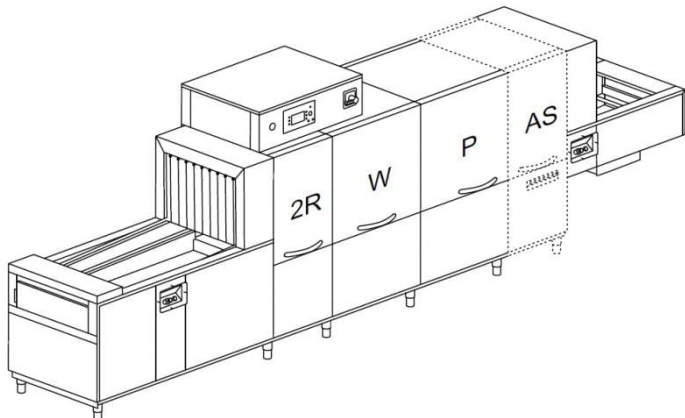



## GALLERY IMAGES

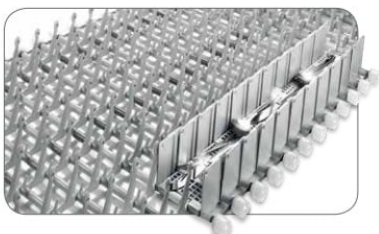

## PRODUCT DESCRIPTION

The QX 416 - High-performance, continuous belt dishwasher with drying zone, capacity: 3200/4820

plates / hour. The size of the loading opening: 710mm wide and 450mm high. This allows you to accommodate restaurant trays or 3 rows of plates at a time. Components (4 pcs): “down-pre-shower” zone (AS), pre-wash (P), wash (W) and double flush zone (2R). These components are aided by the following features: 5-speed belt drive, 5.7 "color TFT display, touch-button control, continuous monitoring of key operations; multilingual menu system, fault diagnosis, alarm and event log. Insulated stainless steel boiler (AISI 316). double rinsing of the belt dishwasher for better efficiency and lower energy consumption Water consumption: 309 liters / hour, maximum conveyor speed: 1.6 m / min. The QX 416 - belt dishwasher comes standard with a conveyor belt and a cutlery belt for washing glasses, plates, trays and dishes. Options: 5 different conveyors; water, energy consumption and operating time monitoring system; steam condenser, peristaltic chemical dispensers, wifi connection, extra heat and sound insulation, boiler power increase. Possible operating modes of the dryer unit: off state, fan only, 50% heating power (4.5 kW) + fan, 100% heating power (9kW) + fan. Heat recovery: The heat recovery system allows the dishwasher to be supplied with cold water (8-15 ° C), while at the same time providing significant energy savings. The steam generated during operation condenses in the heat exchanger, the resulting heat energy preheats the incoming water, thus reducing energy consumption. The use of a water softener is mandatory!

## ADDITIONAL INFORMATION

<b>Weight</b>	845 kg
<b>Dimensions</b>	1185 × 5600 × 2060 mm
<b>Brand</b>	<a href="#">DIHR</a>
<b>Packaging dimension (Wi)</b>	<a href="#">5600</a>
<b>Packaging dimension (De)</b>	<a href="#">1185</a>
<b>Packaging dimension (He)</b>	<a href="#">2060</a>
<b>External size (Wi)</b>	<a href="#">5400</a>
<b>External size (De)</b>	<a href="#">985</a>
<b>External size (Hi)</b>	<a href="#">1860</a>
<b>Gross weight (kg)</b>	<a href="#">845</a>
<b>Voltage (V/Hz)</b>	<a href="#">400/50</a>
<b>Power (W)</b>	<a href="#">33500</a>
<b>Basket dimensions (mm)</b>	<a href="#">500 x 500</a>
<b>Number of baskets</b>	<a href="#">3200-4820 dishes/hour</a>
<b>Washing up efficiency (basket/hour)</b>	<a href="#">3200-4820 dishes/hour</a>
<b>Tank capacity (l)</b>	<a href="#">100</a>
<b>Maximal dish size (mm)</b>	<a href="#">450</a>
<b>Net weight (kg)</b>	<a href="#">745</a>



